



## **Request for Proposal (RFP) – 2<sup>nd</sup> Round**

Retail Artisan /Straw Market Kiosks and Mobile Carts

March 21, 2025

**\*If you submitted a response to the first RFP, please do not resubmit your response. This second posting of the RFP is only for new applicants.**

### **IMPORTANT CONFIDENTIALITY STATEMENT**

The information in this Request for Proposal (RFP) is owned by CARNIVAL CORPORATIONS and must remain confidential. Your acceptance of this RFP for review and response constitutes agreement to maintain this document in confidence. You will not disclose this document or discuss the contents with any third party or individual other than your own employees, consultants, and independent contractors on a strict need-to-know basis, and you will ensure that any individual to whom you disclose the document is aware of its confidential nature. If you do not or cannot agree with this Confidentiality Statement, you should immediately return the document to the sender and delete any soft copies without reviewing the contents.

## TABLE OF CONTENTS

<b>1</b>	<b>INTRODUCTION.....</b>	<b>3</b>
<b>2</b>	<b>BACKGROUND &amp; OVERALL OBJECTIVES OF RFP .....</b>	<b>4</b>
<b>3</b>	<b>PROCESS SCHEDULE .....</b>	<b>5</b>
<b>4</b>	<b>VOLUMES / TECHNICAL SPECIFICATIONS .....</b>	<b>6</b>
<b>5</b>	<b>EVALUATION CRITERIA .....</b>	<b>6</b>
<b>6</b>	<b>SUPPLY BASE.....</b>	<b>7</b>
<b>7</b>	<b>RFP – SOURCING PROCESS AND GUIDELINES.....</b>	<b>7</b>
7.1	STRUCTURE OF THE RFP .....	7
7.2	SUBMISSION OF RESPONSES .....	7
7.3	SELECTION PROCESS .....	7
<b>8</b>	<b>ADMINISTRATIVE REQUIREMENTS .....</b>	<b>7</b>
8.1	CONTACT INFORMATION .....	7
8.2	RFP QUESTION AND ANSWER PROCESS.....	7
8.3	SPECIFICATION ERRORS .....	8
8.4	FORMAT .....	8
8.5	CONFIDENTIALITY .....	8
8.6	NO REFERRALS.....	8
8.7	ALTERNATIVE PROPOSALS .....	8
8.8	PRESENTATIONS.....	9
8.9	GENERAL .....	9
8.10	ELECTION NOT TO SUBMIT RESPONSE .....	9
8.11	LATE SUBMISSIONS .....	9
8.12	RFP AMENDMENTS.....	9
8.13	RESPONSE PREPARATION .....	9
8.14	OFFER EXPIRATION DATE .....	9
8.15	DESIGNATION OF REQUIREMENTS .....	9
8.16	AWARD OF PROJECT BUSINESS .....	9
8.17	POST-RFP DEBRIEFING .....	10
8.18	DISCLAIMER.....	10
8.19	CONTRACT TERMS AND CONDITIONS .....	10
<b>9</b>	<b>APPENDIX .....</b>	<b>11</b>
9.1	ATTACHMENT 1: STATEMENT OF WORK(SOW).....	11
9.2	ATTACHMENT 2: RFP QUESTIONNAIRE AND COST TABLE.....	15

## 1. Introduction

Carnival Corporation & plc, the world's largest leisure travel company, provides travelers around the globe with extraordinary vacations at an exceptional value. The company's portfolio of global cruise line brands includes nine (9) distinct brands operating worldwide. Together, these brands comprise the world's largest cruise company with a fleet of over 90 ships visiting more than 700 ports around the world. For more information, please visit <http://www.carnivalcorporation.com/>.

Celebration Key is Carnival's first-ever exclusive destination to be purpose-built for Carnival Cruise Line guests and is located on the south side of the larger island of Grand Bahama. It offers unique and authentic experiences for all our guests to experience the ultimate tropical paradise where they can choose how to vacation. Whether it's taking the time to relax and rejuvenate, take part in all the activities offered within the destination, or just take in the paradise, there is something for every type of vacationer.

The adjacent cruise pier will be able to accommodate up to two of Carnival's Excel-class ships simultaneously and capable to welcoming - 2 million guests each year. Supporting our commitment to the Bahamas, the project was recently increased to allow two additional vessels for a total of four ships that will allow guests to walk off and arrive at Celebration Key.

Enjoy the largest freshwater lagoons in the Caribbean, a breathtaking mile-long beach, the natural beauty of our home in Grand Bahama and five unique portals (Paradise Plaza, Calypso Lagoon, Lokono Cove, Starfish Lagoon and Pearl Cove Beach Club) crafted to provide a variety of experiences for our guests. These experiences range from family or adult fun, relaxing or adventurous fun, private or social fun, pool or ocean fun, shopping, or eating & drinking fun, all with a local Bahamian flavor. Therefore, Celebration Key is uniquely positioned to bring an island experience to our diverse range of guests, in a way that lets them choose their slice of 'paradise' and its official tagline is Your Key to Paradise.

Celebration Key™ opens in July 2025.



## 2. Background & Overall Objective of the RFP

Carnival Corporation & plc via its subsidiary Carnival Grand Bahama Investments Limited (“Carnival”) is requesting proposals from businesses (“Operators”) interested in participating in the development and leasing of small retail artisan/ straw market stalls and mobile carts (“Retail”) at Celebration Key, currently under construction by Carnival at Sharp Rock on Grand Bahama Island (“the Destination”), approximately thirteen (13) miles from downtown Freeport.

Carnival is constructing a dedicated cruise ship destination designed to accommodate two cruise ships per day, with a daily onshore capacity of up to 13,000 guests and 4,000 crew members. The Destination is expected to welcome 2M+ passengers annually, and ship are expected to call almost every day of the year, including holidays.

The Groundbreaking ceremony took place on May 12, 2022, and construction is underway. The Destination is expected to open July 2025.

Retail at the Destination is being designed to provide a diverse retail experience for several thousand guests and crew across a variety of daily operational scenarios. The Destination will primarily receive ships in port from 8 a.m. to 5 p.m. Night operations are being designed for and to be considered. Stores must remain open every time a ship is in port.

Retail footprint at the Destination is not dense and will be differentiated by being Bahamian- focused and inspired.

In order to provide a quality Retail experience, Carnival will negotiate and execute lease agreements with many qualified Operators. Agreements may take the form of standard and/ or long-term retail leases.

For more information please visit <https://www.CelebrationKeyGrandBahama.com/> and follow us on Social Media:

- Instagram: <https://www.instagram.com/celebrationkeygrandbahama/>
- Facebook: <https://www.facebook.com/people/Celebration-Key-Grand-Bahama/61552410317019/>

More details are included in the SOW, see exhibit A.

Operators will be expected to comply with all local Grand Bahama, Bahamas laws and regulations concerning the operation of their business at Celebration Key.

Carnival reserves the right to adjust the criteria at its discretion.

Carnival reserves the right to accept, challenge and reject any or all responses at its complete discretion.

### 3. RFP Process Schedule

For this Request for Proposal, Carnival has established the following timeline for the completion of the RFP process. Potential Operators not responding by these due dates may be disqualified:

<b>Sourcing Process</b>	<b>Due Date</b>
Request for Proposal Posted on the Website - <b>Repost</b>	3/21/2025
Operator Questions Due to Carnival	3/26/2025
Carnival Answers to Operators	3/31/2025
<b>RFP Responses Due</b>	<b>4/04/2025</b>
Carnival RFP Review and Evaluation	By 4/11/2025
Operator Presentations (if asked for by Carnival)	Week of 4/14/2025
Preferred Operator(s) selected	4/23/2025
Business Award Notification sent	4/25/2025
Finalize Leasing Agreements	5/15/2025

## 4. Volume

As detailed in the attached SOW, there are:

1. 14 (east) + 10 (west) = 23 total artisan/straw market stalls, are located in an open designated area, in 2 buildings under roof with ceiling fans.
2. 10 kiosks for small retail, “mobile retail cart”; located either in the retail village, or in designated, smaller “retail” area by the food truck clusters

Please note volumes are subject to change according to any fluctuating business requirements and no amount shall be contractually binding upon Carnival Corporation in any contract resulting from this RFP.

## 5. Evaluation Criteria

Request for Proposal evaluation will be based on all elements of each response, including intangible factors such as CARNIVAL’s assessment of each Operator’s ability to meet its commitments. **Responses not meeting Minimum Requirements may be disqualified and may not be considered for award.** CARNIVAL reserves the right to accept or reject any or all responses at its complete discretion and to negotiate the terms of any subsequent agreements. As aforementioned, CARNIVAL is looking for reliable, financially stable Operators who can meet or exceed CARNIVAL’s stringent cost, quality, and service requirements. Specifically, these requirements are:

- **Minimum Requirements**
  - Complete responses must be received on or before due date.
  - **Responses must include all required information asked in the RFP questionnaire worksheet.**
  - Operators must read and follow all instructions and guidelines.
  - **Operators must provide pictures of products with description and price**
  - Operators must provide certificate of insurance or evidence of insurability.
- **Company**
  - Capabilities and experience
  - Financial health
  - Divisional, Corporate, Affiliate, Franchise, Partnership or Network standards and control.
- **Service Quality**
  - Approach and timeline
  - Statement of Work
  - Performance and reliability
  - Integration and standardization with CARNIVAL business and processes
- **Deliveries**
  - Service Level Agreement and Guarantee
- **Financials**
  - Detailed cost breakdown and ability to remain below price ceilings

CARNIVAL does not represent that these are the sole evaluation criteria and reserves the right to adjust the criteria at its discretion.

## 6. Supply Base

The successful Operators must exhibit the experience and capability of providing Bahamian focused and inspired goods for Straw market stalls and mobile carts (Kiosks); while demonstrating the ability to properly stock and replenish their inventory of goods so there are no business interruptions. Also, Operators are expected to price their goods competitively and remain below the identified price ceiling of \$50/ \$75. It is CARNIVAL's objective to select an Operator for each available stall and mobile cart.

**In this second round of the Request for Proposal (RFP) we are specifically requesting the following types of Artisan items.**

- **Unique Bahamian art (paintings and prints)**
- **Local wood carving**
- **Conch shell and sea glass jewelry**
- **Unique Straw Items**
- **Junkanoo inspired artisan items (travel friendly)**
- **Other authentically created Bahamian created Artisan items**

CARNIVAL reserves the right to select as many operators as it deems appropriate and is under no obligation to purchase any products and/or services of a particular Operator until an agreement has been reached. Furthermore, CARNIVAL is not bound to explain its selection decision. Operators failing to comply with the requests in this document may be disqualified.

## 7. RFP – Sourcing Process and Guidelines

The RFP was posted on the Celebration Key website and should be returned to the CARNIVAL contact.

### 7.1 Structure of the RFP

The RFP consists of a SOW, set of questions for which pricing is requested. Operators must respond to all questions.

### 7.2 Submission of Responses

All responses must be submitted in writing by return e-mail to the CARNIVAL contact. Other forms of submissions will not be accepted unless explicitly stated or for practical purposes such as providing samples.

### 7.3 Selection Process

Operator selection is based upon CARNIVAL's overall assessment of submitted responses, including but not limited to qualitative information that may have been received via a Request for Proposal (RFP), prior experience with CARNIVAL, Operator capabilities, innovation, and footprint. See section 5 "Evaluation Criteria" for more information.

## 8. Administrative Requirements

### 8.1 Contact information

The individual listed below is the main point of contact for this RFP.

Erika Claxton  
Senior Manager, Global Strategic Sourcing of Port Destinations  
Email: eclaxton@Carnival.com  
Phone: 954-242-7969

## **8.2 RFP Question and Answer Process**

CARNIVAL will allow written requests for clarifications of the RFP, to be submitted via e-mail. CARNIVAL will respond to Operator questions via e-mail no later than the timeline set forth in section 3 “Process Schedule”. Operator’s name will be removed from questions in the response released if a summary response is issued by CARNIVAL. By publishing the document, we seek to avoid as much misinterpretation as possible and provide the same information to each Operator to prevent any Operator from having an advantage over others.

Questions should be sent directly to the CARNIVAL contact, making clear reference to this RFP, and submitted by email.

A single document listing questions and the CARNIVAL answers to those questions may be issued to all Operators via e-mail versus individual responses.

## **8.3 Specification Errors**

If any of the specifications provided are unclear, or if Operators know them to be inaccurate, the Operator should inform CARNIVAL. The Operator should state the nature of the inaccuracy or lack of clarity in detail and suggest a resolution. CARNIVAL contact will assess the matter and respond accordingly to all Operators.

## **8.4 Format**

CARNIVAL reserves the right to reject any or all responses submitted that fail to conform to the requirements of the RFP and to request additional information from any vendor submitting a response.

## **8.5 Confidentiality**

The information contained in this RFP is Confidential Information. Confidential information may be disclosed between the parties as part of this RFP process. In order to protect any confidential information, the parties hereby agree as follows:

1. Receiving party agrees to hold all confidential information whether disclosed in writing or orally in confidence for a period of three (3) years from the disclosure of confidential information.
2. The receiving party shall protect the disclosing party’s confidential information by using the same degree of care as the receiving party uses to protect its own confidential information, but no less than a reasonable degree of care, to prevent the unauthorized use, dissemination, or publication of the confidential information.

This information packet does not impose an obligation on the receiving party with respect to confidential information that the receiving party can prove: (a) was lawfully in their possession before receipt from the disclosing party; (b) is or becomes a matter of public knowledge through no fault of the receiving party; (c) is rightfully received by the receiving party from a third party without a duty of confidentiality; or (d) is disclosed by the receiving party with the disclosing party’s prior written consent.

## **8.6 No Referrals**

Operator may not refer or pass this RFP to another Operator without prior approval from CARNIVAL.



### **8.7 Alternative Proposals**

CARNIVAL has taken great care in ensuring that requirements are functionally stated and expects Operator to respond to those requirements in the outlined standard format. CARNIVAL is open to investigate alternative solutions offered by the Operator if they provide a significant advantage over the desired and outlined requirements.

### **8.8 Presentations**

CARNIVAL will require a presentation of all or shortlisted Operators. Operators will be provided with an advanced notice of the suggested dates and is responsible for leading their presentation via in person or Microsoft Teams call.

### **8.9 General**

It is important that Operators acknowledge any of the stated requirements in this RFP that cannot be met in full. Any information received by CARNIVAL in response to this RFP may be utilized at no charge to CARNIVAL, whether or not the Operator is invited to participate in the RFP exercise, or a contract is awarded to such Operator, unless such information is described in a prior written notice to CARNIVAL as proprietary to the Operator.

### **8.10 Election Not to Submit Response**

If you elect not to proceed with submission of a response, please inform the issuer of this document as outlined in 8.1 "Contact Information".

### **8.11 Late submissions**

Responses submitted after the closing date will not be accepted. CARNIVAL is not responsible for the late delivery or responses lost in the delivery. Operators must notify the CARNIVAL contact if there is an extenuating circumstance that may prevent on-time delivery.

### **8.12 RFP Amendments**

CARNIVAL reserves the right to amend this RFP at any time prior to the closing date. Amendments will be issued only to Operators who are going to complete a response. No other amendments, verbal or otherwise will be acknowledged by CARNIVAL.

### **8.13 Response Preparation**

Responses should be prepared simply and economically without emphasis on the presentation of the submission. Expensive bindings, color photographs and excessive promotional materials are neither desired nor needed. Operator may electronically submit brochures if requested but should not include materials not requested.

### **8.14 Offer Expiration Date**

Responses to this RFP will be valid for the duration of one hundred and twenty (120) days from date of submission of response to the RFP.

### **8.15 Designation of Requirements**

Operators must respond to all mandatory requirements presented in this RFP. Failure to respond to mandatory requirements may disqualify your response.

### **8.16 Award of Project Business**

This RFP should not be construed as an offer to contract; only the execution of an executed contract will obligate CARNIVAL in accordance with the terms and conditions in such contract.

At this stage it is expected that any contract resulting from this RFP process is likely to be under US law.

### **8.17 Post-RFP Debriefing**

CARNIVAL will, upon request, offer to debrief Operators who were disqualified or did not move beyond the RFP to subsequent milestones in the sourcing process. Operators may request to be debriefed via telephone conference or email.

### **8.18 Disclaimer**

All costs for preparing and submitting this Request for Proposal are to be borne by the Operator. CARNIVAL is under no obligation to reimburse any Operator for any costs associated with preparing and/or submitting a response whether or not the Operator is selected. This RFP does not commit CARNIVAL or any official of it to any specific course of action. The issuance of this RFP does not bind CARNIVAL or any official of it to accept any submission, in whole or in part, nor does it bind any official of CARNIVAL to provide any explanation or reason for its decision to accept or reject any submission. Moreover, while it is the intention of CARNIVAL to enter final negotiations with the selected vendor for this project, the fact that CARNIVAL has given acceptance to a Operator does not bind it or any official of it to purchase any product or service from such a Operator.

### **8.19 Contract Terms and Conditions**

All goods and/or services being offered by Operator in its response to this RFP herein are assumed to be valid under the terms and conditions as outlined in the agreement provided via the RFP, if applicable.

Do not send your standard contract. Your comments, if any, relating to the provided agreement will be evaluated and our evaluation will comprise part of the selection process.

All suggested additions / deviations to this agreement must be noted in the response in RFP. If your noted additions / deviations to this agreement have a negative impact on the pricing (in subsequent sourcing phase(s)), please quantify the impact of this for CARNIVAL in your notes in RFP.

## 9. Appendix

### EXHIBIT 1 - Statement of Work (SOW)

#### Straw Market and Artisan Kiosks for Celebration Key

##### Overview

This Statement of Work (SOW) outlines the specifications for the development, operation, and leasing of artisan/straw market stalls and retail kiosks (mobile carts) at Celebration Key a cruise destination port in Grand Bahama, Bahamas. The purpose of this initiative is to provide local artisans and small retailers an opportunity to sell goods to visitors in designated markets and retail areas while maintaining specific guidelines related to pricing, structure, and operational hours.

This SOW outlines the key responsibilities and expectations for operators leasing artisan/straw market stalls and retail mobile carts (kiosks) at the cruise destination port. Detailed lease agreements and pricing structures will be provided during the finalization phase of this project.

**In this second round of the Request for Proposal (RFP) we are specifically requesting the following types of Artisan items.**

- **Unique Bahamian art (paintings and prints)**
- **Local wood carving**
- **Conch shell and sea glass jewelry**
- **Unique Straw Items**
- **Junkanoo inspired artisan items (travel friendly)**
- **Other authentically created Bahamian created Artisan items**



## 1. Artisan/Straw Market Stalls

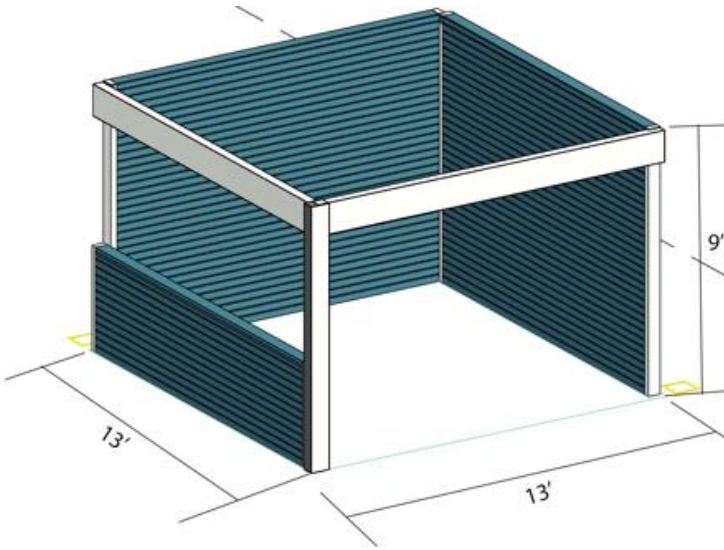

### 1.1. Quantity and Location

There are **24 total artisan/straw market stalls**:

- **14 stalls on the East side**
- **10 stalls on the West side**

Each stall has a general dimension of approximately **13' x 13'** and is located within two designated market buildings with roofs. The market area is open-air, with fans to be installed for ventilation and comfort.

### 1.2. Structure and Design

- Each stall will be equipped with an entrance and a front-facing counter to facilitate transactions and customer engagement.
- The stalls are provided by **Celebration Key** and modifications or customizations will be minimal and standardized across all stalls.

### 1.3. Lease Terms

- Rent for the stalls will be similar across the market, though exact pricing will be detailed in lease agreements.
- Artisans and vendors will be required to adhere to the pricing guidelines, which include a **price ceiling of \$50/\$75** on goods sold to ensure affordability for guests. All items must be priced below this ceiling.

## 2. Retail Kiosks/ Mobile Carts

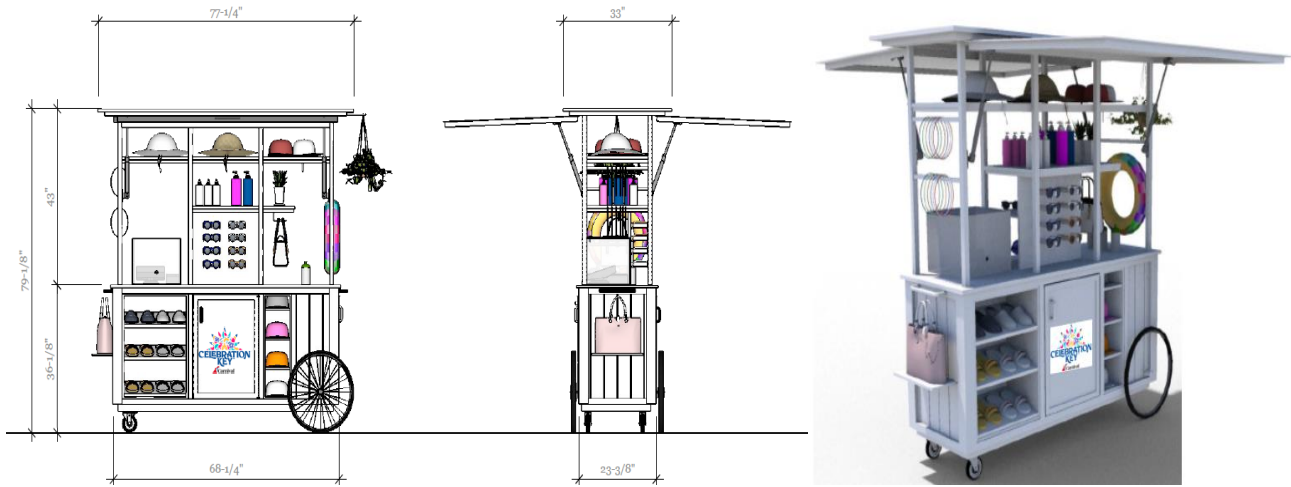

### 2.1. Quantity and Location

- There are **10 retail mobile carts (Kiosks)**, each designed to accommodate small-scale retail operations.
- These mobile carts will be located in two key areas:
  - **The Retail Village**
  - Also in smaller, designated **retail zones** near food truck clusters.

### 2.2. Structure and Design

- The kiosks will be standardized in terms of appearance and functionality, with the ability to lock and secure merchandise outside of operating hours for vendor safety.
- Any required customization of the kiosks will be determined by **Celebration Key** and communicated prior to installation.

### 2.3. Lease Terms

- Retail mobile cart rent will be consistent across all units.
- Vendors must comply with the established **price ceiling**, ensuring that all items sold are below this cap.

## 3. Payment Terms and Price Ceiling Enforcement:

- All goods are sold as Point of Sale (cash or debit/credit card) - Guests will be charged directly by the Operator for all Retail purchases. Existing Bahamian brands, or brands uniquely created for the Destination, are preferred.
- All Straw market stalls, and retail kiosks are subject to a **price ceiling of \$50/\$75** on goods sold. This ensures a fair and competitive market while maintaining affordability for cruise passengers. Vendors found violating these pricing guidelines may face penalties, including potential termination of lease agreements.

#### **4. Responsibilities**

##### **Operators:**

- Operators will be asked to potentially build-out the store at their risk and expense, etc., depending on the concept. Operators will have to provide construction plans for Carnival's approval prior to starting work for Carnival approval.
- Operators are responsible for the cleanliness and daily operation of their stalls or mobile cart, ensuring they remain in good condition.
- Operator will have to maintain inventory levels to continue daily operations of selling approved goods for the mentioned daily onshore capacity of up to 13,000 guests and 4,000 crew members.
- Inventory/ storage will have to be managed by the Operator's offsite, or in the store for small, high turnover items. No replenishment of inventory should take place during operations but can be done prior to ship arrival or after ship departure.
- Operators will be asked to potentially build-out the store at their risk and expense, etc. Tenant will have to provide construction plans for Carnival's approval prior to starting work for Carnival approval.
- Operators must lock and secure their kiosks outside of these hours.

##### **Carnival:**

- Carnival will ensure that the retail offering is varied; however, some product categories may overlap between stores.
- Operating hours will be communicated by **Carnival**.

#### **8. Timeline:**

- Execution of Lease Agreement: April 2025
- Retail space design approval by: May 2025
- Conduct Retail space build-out: May 2025
- Carnival's final approval and sign-off: May 2025

## EXHIBIT B: ATTACHMENT 2

Please complete the below questionnaire in the attached excel worksheet. All respondents must submit RFP responses in this format.

**Submit any questions you may have before March 26th.**

**As stated in the timeline of the RFP, response are due no later than April 4, 2025.**

<b>Company name</b>	
<b>Contact Name</b>	
<b>Contact Phone Number</b>	
<b>Contact Email Address</b>	

<b>Response Date :</b>

1. Straw Market Stalls and Retail Kiosks(Mobile Carts)		
#	Questions	Response
1	Are you applying for a <b>Straw market stall or Retail mobile cart?</b>	
2	<b>Business Profile:</b> Can you provide a brief background of your business, including years in operation and product focus?	
3	<b>Ownership:</b> Are you a Bahamian owned and operated business? Are your products locally sourced or handmade? If no, please explain.	
4	<b>Experience:</b> Have you previously operated in similar retail environments (e.g., cruise ports, outdoor markets, tourist destinations)? If yes, please share details.	
5	<b>Retail Concept:</b> Please provide a detailed description of the retail concept, including products/ services you intend to sell; please also attach pictures and/or additional descriptions to your submittal in MS Word or PowerPoint.	

6	<b>Product Origin:</b> Can you provide information on where your products are made and how they reflect the local culture or craftsmanship of the Bahamas?	
7	<b>Sustainability:</b> Do your products incorporate eco-friendly or sustainable materials?	
8	<b>Inventory Management:</b> How do you plan to handle stock replenishment and manage inventory know ?	
9	<b>Cart/Stall Design:</b> Can you provide a description or visual of your proposed mobile cart or straw market stall setup? Does it reflect “Bahamian focused or inspired” branding, or how would you tailor your concept/theme/brand to be more aligned with the Vision?	
10	<b>Alignment with the Vision:</b> Is the brand uniquely created for the Destination? If not, would you be willing to create a brand uniquely for the Destination?	
11	<b>Permits and Licenses:</b> Do you have the necessary licenses and permits to operate in the Bahamas? Please provide details.	
12	<b>Insurance:</b> Do you have business liability insurance? If so, what's the coverage? If not, are you willing to purchase a policy to do business with Carnival?	
13	<b>Pricing Strategy:</b> What is your pricing strategy, and how do you plan to keep your products competitively priced for tourists and under price ceiling of \$50/\$75?	
<b>1.2 Additional Attachments Area</b>		

**End of RFP**